

A DYNAMIC HYBRID MODEL OF A VEHICLE CLUTCH FOR HiL APPLICATIONS

S. Helm, S. Winter, M. Kozek
Vienna Univ. of Technology, Austria

Corresponding author: S. Helm, Vienna Univ. of Technology, Inst. f. Mechanic and Mechatronic
1040 Wien, Wiedner Hauptstraße 8-10, Austria, Siegfried.Helm@tuwien.ac.at

Abstract. The purpose of the presented approach is to present a dynamic, hybrid model of a friction clutch for a hybrid vehicle. The clutch model itself is based on a hybrid state machine, programmed as an external C-function for Dymola and incorporates a friction model which depends on the relative speed of the clutch plates. The state machine is represented by 3 discrete states 'open', 'closed' and 'reopening' and can be parameterized by a small number of parameters. The model of the vehicle clutch is then integrated into a complete model of a hybrid vehicle and tested in a simulation as well as on a Hardware in the Loop test bench. Therefore the clutch model has a real-time capability.

1 Introduction

Due to the competition between car manufacturers, engineers in automotive industry have to develop new methods to evolve existing vehicle concepts or even design new ones [5], [3], [2]. To achieve this goal, new design techniques like Hardware-in-the-Loop (HiL) simulation have been successfully implemented [9], [8], [1]. This technique combines the advantages of both simulation (flexibility and adaptivity) and test bench experiments (significant and valid results).

To perform those HiL tests two important elements are necessary: The first one is a suitable test bench environment. In the presented case a test bench for internal combustion engines is used to conduct the tests. The second requirement is an accurate mathematical model of the system to be simulated.

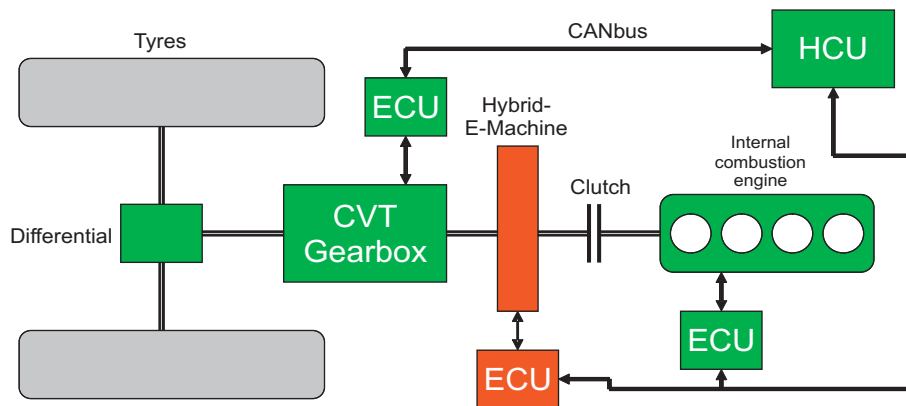

Figure 1: Basic structure of the Hybrid vehicle

In the case under consideration the model is based on a hybrid vehicle's power train consisting of an internal combustion engine (ICE), a hybrid electric motor (HEM), a continuously variable transmission (CVT) gearbox, a differential, as well as the vehicle's tyres and the component's control units as they are depicted in Figure 1. The simulation model of the vehicle is an extensively modified version of the longitudinal-dynamics-model introduced in [5], which was created using the Modelica-Dymola simulation environment. The vehicle model also contains a driver model (PID-controller), which is used to generate an acceleration and a break pedal signal, according to the desired driving condition.

One of the most important components of the power train, the vehicle clutch, is situated between the ICE and the HEM. However, creating a correct clutch model is challenging since the system equations of the clutch are highly nonlinear due to the fact that the friction between the clutch plates depends on the relative speed between the clutch plates. Moreover, the non-linear differential equations of the drive-train model change generically for different operating states of the clutch.

So the presented hybrid model's nonlinear equations have to be adapted accordingly for HiL tests. This is accomplished by replacing parts with a high mechanical stiffness with completely rigid elements, if they are not essential for the particular subject matter. As an example, stiffness of the shafts can be neglected since strong accelerations do not occur in the driving cycle. Another aim for the model is the capability of easy parametrisation. Thus, the

clutch model can be used in miscellaneous models of vehicle power trains of different vehicle classes by adapting an individual set of clutch parameters.

2 Model features

Figure 2 shows a simplified model of a real vehicle clutch in compound with the simplified remainder of the vehicle's power train. Here the combustion torque M_C , generated by the engine acts on the simplified crankshaft inertia J_{CS} ([6] and [7]). The clutch itself is represented by two rotating plates (ω_1, ω_2) with inertia J_{CL} as well as a rotational spring-damper element (k, d), which represents the elastic stiffness of the vibration damper of the clutch. The second clutch plate is coupled to the reduced inertia J_{GB} of the power train and the vehicle. The value of the inertia J_{GB} depends on the chosen gear in the gearbox and incorporates the inertia of the gearbox, the differential, as well as the vehicle's tyres and the reduced inertia of the vehicle's mass.

A crucial point in modeling system components for HiL simulation is the ability to simulate the model on a realtime simulation platform. Since the model behavior is governed by its nonlinear system equations, which are time-consuming to solve, it is necessary to optimize the model in an appropriate way. To do so, certain features of the real system, such as the stiffness of shafts, are neglected if they are not essential for the particular subject matter as it is mentioned in chapter (1).

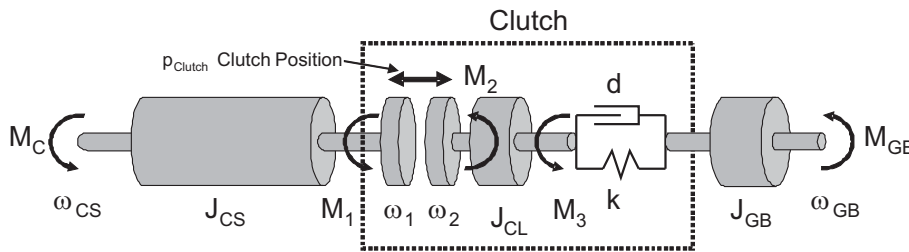

Figure 2: Model of the friction clutch

A mathematical description of the system depicted in Figure 2 is given by the following formulas. The dynamic model of the clutch is based on a hybrid state machine, which is defined by three discrete states. Each state is constituted by an algebraic equation of system variables:

State "closed":

$$(J_{CS} + J_{CL}) \cdot \dot{\omega}_{CS} = M_C - M_3 \quad (1)$$

$$J_{GB} \cdot \dot{\omega}_{GB} = M_3 - M_{GB} \quad (2)$$

$$\omega_{CS} = \omega_1 = \omega_2 \quad (3)$$

During clutch state "closed" the the behavior of the clutch is represented by two differential equations (1 and 2) and a kinematic constraint (3). Due to the rigid connection between the inertias J_{CS} and J_{CL} the speed ω_1 and ω_2 are identical according to equation (3).

States "open" and "reopening":

$$J_{CS} \cdot \dot{\omega}_{CS} = M_{CS} - M_1 \quad (4)$$

$$J_{CL} \cdot \dot{\omega}_2 = M_2 - M_3 \quad (5)$$

$$J_{GB} \cdot \dot{\omega}_{GB} = M_3 - M_{GB} \quad (6)$$

The two states "open" and "reopening" can be described by three coupled differential equations (4, 5 and 6). The clutch torque transferred between the clutch plates, M_1 and M_2 , respectively, is then calculated by the well known formula:

$$M_1 = M_2 = M_{Clutch} = n \cdot F_n \cdot r_f \cdot \mu_{dyn} \quad (7)$$

In (7) the number of engaged clutch plates is denoted by n , the axial force acting on them is F_n , the friction radius of the clutch is r_f . They are all constant clutch parameters. The dynamic friction coefficient μ_{dyn} depends on the material of the clutch plates as well as on the relative velocity between the plates. In a formal notation μ_{dyn} is defined as:

$$\mu_{dyn} = \mu_H + \mu' \cdot v_{rel} \quad (8)$$

$$\mu' = \frac{\partial \mu}{\partial v_{rel}} \tag{9}$$

Figure 3 shows a graph of the dynamic friction coefficient μ_{dyn} , used for the simulation according to equation (8). Since the real characteristic of the coefficient is only approximately known, a linear relationship between the relative speed and the dynamic friction coefficient was chosen. The linear relationship is valid within the lower ($v_{rel} = 0$) and the upper limit ($v_{rel} = v_{sat}$). At a relative speed of 0 m/s at r_f the dynamic friction coefficient is equal to the static friction coefficient and decreases with increasing relative speed until v_{rel} is equal to or bigger than v_{sat} . This is the case for common friction materials for vehicle clutches.

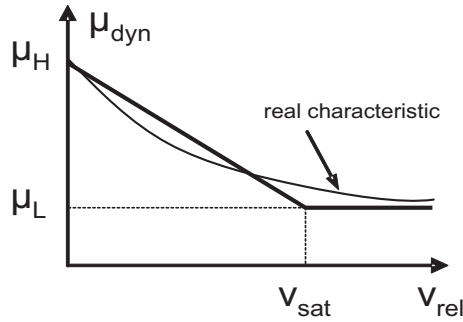

Figure 3: Relative-speed-depending dynamic friction coefficient μ_{dyn}

The initial state of the state machine is 'open'. If the clutch pedal position exceeds a certain value and the relative speed of the two clutch plate is smaller than a predefined threshold, the state machine executes a transition to the state 'closed'. By defining a third state "reopening" it is possible to reproduce an highly undesirable effect called bucking. This is possible since the transition condition between the two states "closed" and "reopening" is defined by a comparison of the actually transmitted dynamic torque according to equation (7), and the static torque M_{stat} which can be transferred under current conditions ($M_{stat} = n \cdot F_n \cdot r_f \cdot \mu_{stat}$), according to Figure 4. If the dynamic torque exceeds the static torque the state machine executes a transition to the state "reopening", where the relative speed between the plates is nonzero. As long as the state "reopening" is active, the clutch is able to transfer a torque defined by equation (7). If the relative speed v_{rel} exceeds a certain threshold, the state machine switches to the state "open".

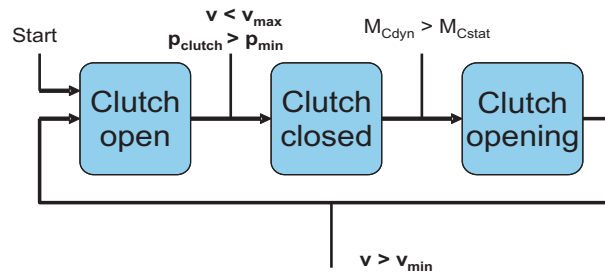

Figure 4: Hybrid State Machine

3 Implementation and Simulation Platform

Equations (1) to (9) as well as the transition conditions between the three states of the state machine are embedded into an external C-function for Dymola. The function has to be defined as a static library since Dymola does not support the more memory-efficient dynamic libraries. The use of the external function is necessary due to the fact that the basic structure of a model can not be changed in Dymola during simulation.

To provide realtime calculations, which means that the time to compute simulation results is limited, it is necessary to use hard-realtime equipment. In the case under consideration the HiL tests are conducted on a MicroAutoBox (MAB) [9], equipped with an IBM Power-PC 750FX (800MHz) and 8MB of main memory. The MAB is also used to establish a connection between all control units of the vehicle using CANbus interfaces which provide CANbus communication at a baud rate of up to 1Mbit/s.

To solve the differential and algebraic equations the MAB provides 5 different fixed-step solvers *ODE1* to *ODE5*. Since the *ODE1* solver was chosen to integrate the differential and algebraic equations of the overall vehicle model numerically, the Euler method is also used to solve the equations (1) to (9) numerically in the C-function at every time step [4].

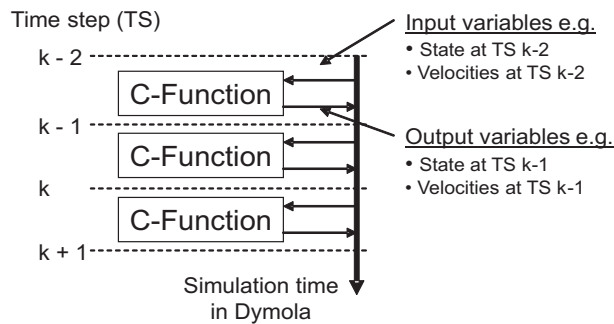

Figure 5: Call of the C-function

As it is depicted in Figure 5, the C-function is called once per time step. Variables like the rotational speed and the clutch state from the previous time step is passed on to the C-function and used for calculation. To do so, the results of the previous time step have to be stored for at least one integration step time. The results of the computation are then transferred back to the simulation of the power train. There, the calculated clutch torque is applied to the flange of the gearbox.

The torque yields a change of the rotational speed of the gearbox as well as a change of the speed of the tyres and subsequent the speed of the vehicle. Both the resulting speed of the gearbox flange and the measured speed of the real engine are then used as an input to the C-function at the following time step. During the process of simulation, the transition conditions are checked once per time step and the state of the state machine is updated as well.

4 Results and Discussion

In the automotive industry standardized drive cycles play an important role as benchmarks e.g. for exhaust gas emissions. The drive cycles contain a prescribed time dependent profile for a vehicle's velocity. To test the clutch model it is integrated into a DYMOLA model of a hybrid vehicle's power train as an external C-function. The overall vehicle power train is initially simulated off-line on an ordinary PC and then transferred to the real time platform dSPACE MicroAutoBox to be simulated under HiL conditions. As a HiL-test object a turbo-charged four-cylinder Otto-engine is used.

The hybrid strategy which governs the interaction of the combustion engine and the HEM also contains a shift strategy. For simulation a Nox-optimized shift strategy is used where the shift points are chosen in such a way that the nitrogen oxide emissions are minimized. For HiL simulation the shift points are set to an engine speed of 250 rad/s for upshifting and 150 rad/s for down-shifting.

4.1 Simulation result: Engagement of the Clutch

Figure 6 shows an off-line simulation result of an engagement of the vehicle clutch. The ICE is operated at a constant speed of 100 rad/s while the speed of the gearbox flange is zero. At $t=1.6$ s the clutch pedal is released and at $t=2.25$ s the clutch state changes from 'open' to 'closed'. Simultaneously the speed of the ICE and the gearbox is aligned to each other. Despite the rigid connection between the two clutch plates at clutch mode 'closed', a mechanical twist between the ICE and the gearbox can occur due to the rotational-damper-element, depicted in Figure 2. Thus the damper-element allows a relative movement between the ICE and the gearbox as it is depicted in Figure 6. The damping of the relative movement is governed by the parameters k and d of the clutch model.

4.2 Simulation Results

Figure 7 shows an off-line simulation result for a single NEDC (New European Drive Cycle, city cycle) of the hybrid vehicle, conducted in Dymola. The engine is started at simulation time 0s and operated at an idle speed of approximately 80 rad/s. After 12 seconds the desired vehicle velocity (blue) is increased, according to the prescribed velocity profile of the NEDC.

The HEM is used to accelerate the vehicle to a velocity of 2.5m/s while the clutch remains in open position. Once the vehicle speed exceeds a velocity of 2.5m/s the control unit of the hybrid vehicle changes the normalized clutch pedal position (red) from 1 (clutch pedal pressed) to 0 (pedal released). Simultaneously, the state of the clutch changes from 'open' to 'closed' which means that the ICE and gearbox speed are being aligned with each other.

After the section of constant speed (at $t=24$ s) the clutch is opened and the HEM is used to brake down the vehicle by recovering and storing the kinetic energy in a battery. Due to the fact that clutch mode during the sections of constant speed is 'reopening' a relative speed between ω_1 and ω_2 and subsequent fluctuations due to mathematical problems can occur. Since the clutch is still able to transfer a torque during the reopening phase the state machine switches to the state 'reopening'. As soon as the relative speed between the clutch plates exceeds a threshold of 40

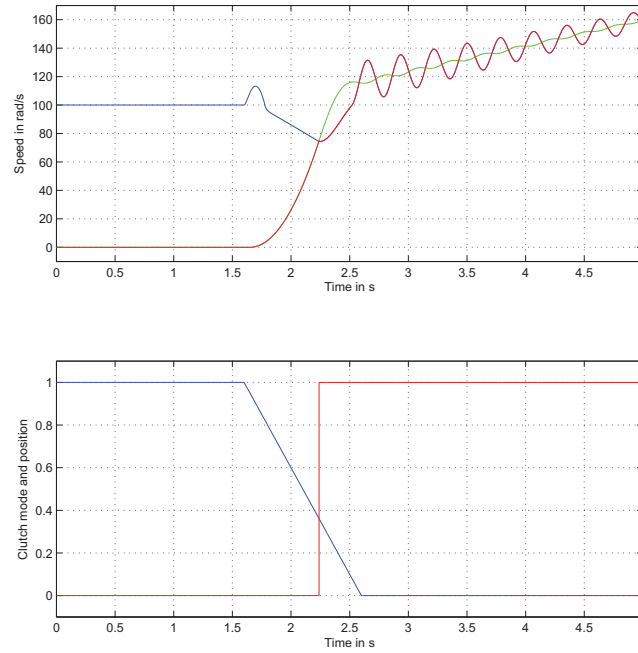

Figure 6: Engaging the Vehicle Clutch: top: ICE speed (blue) and gearbox speed (green), speed of the second clutch plate (red), bottom: clutch mode (red: 0 - open, 1 - closed, 2 - reopening) and position (blue: 1 - pedal pressed, 0 - pedal not pressed)

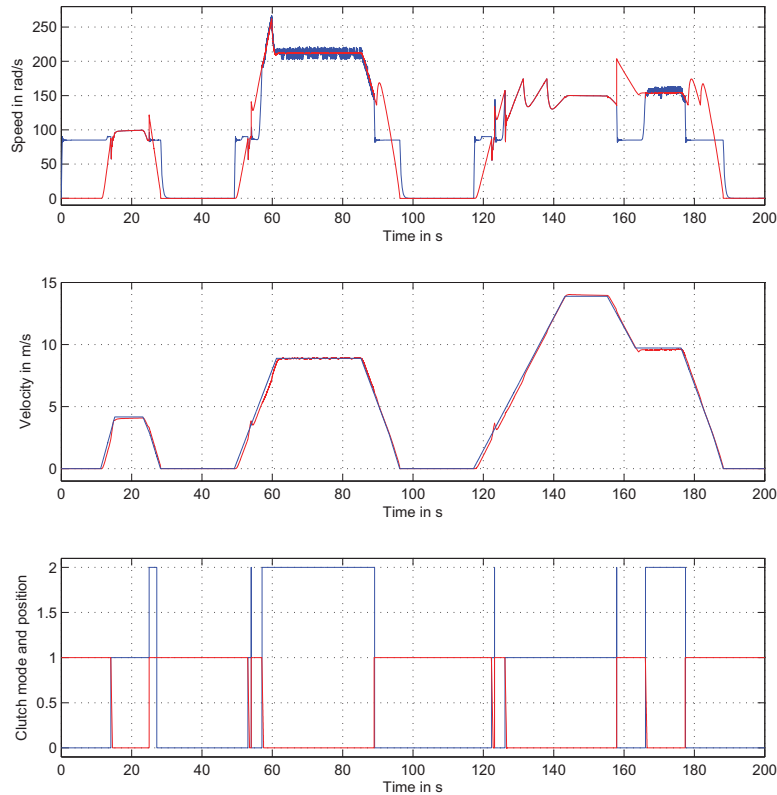

Figure 7: Simulation Results: top: ICE (blue) and gearbox speed (red), middle: desired (blue) and actual vehicle speed (red), bottom: clutch mode (blue: 0 - open, 1 - closed, 2 - reopening) and position (red: 1 - pedal pressed, 0 - pedal not pressed)

rad/s the clutch state changes to "open". The vehicle is decelerated to zero velocity and the engine is subsequently shut down in order to reduce exhaust gas emission.

At $t=50$ s the engine is restarted to accomplish the second segment of the first city cycle of the NEDC. After the vehicle is accelerated by the HEM to a velocity of 2.5m/s the clutch is closed. As the actual vehicle speed exceeds the desired vehicle speed at simulation time 54s the driver model activates the brake pedal to slow down the vehicle and the clutch is simultaneously opened. The clutch state changes to 'reopening' and 'open' since the relative speed of the clutch plates exceeds the threshold of 40rad/s.

At simulation time 57s the clutch is closed again and since the dynamic clutch torque exceeds the static friction torque the state of the clutch is changed to 'reopen'. At simulation time 60s the engine velocity reaches a preset shift point of the CVT gearbox and the gear is changed from first to the second gear. During the section of constant vehicle speed the relative speed between the clutch plates is non zero. During the brake period the clutch is disengaged and the HEM is again used to recover kinetic energy and the engine is shut down. After 117s the engine is started to accomplish the last segment of the city cycle.

4.3 HiL Simulation Results

Figure 8 shows a typical HiL result for a single NEDC (New European Drive Cycle, city cycle). The results of the HiL test are quite similar to the simulation results presented in section (4.2). But carrying out the HiL-tests is challenging since the simulation model has to handle signals from the test bench, corrupted with measurement noise.

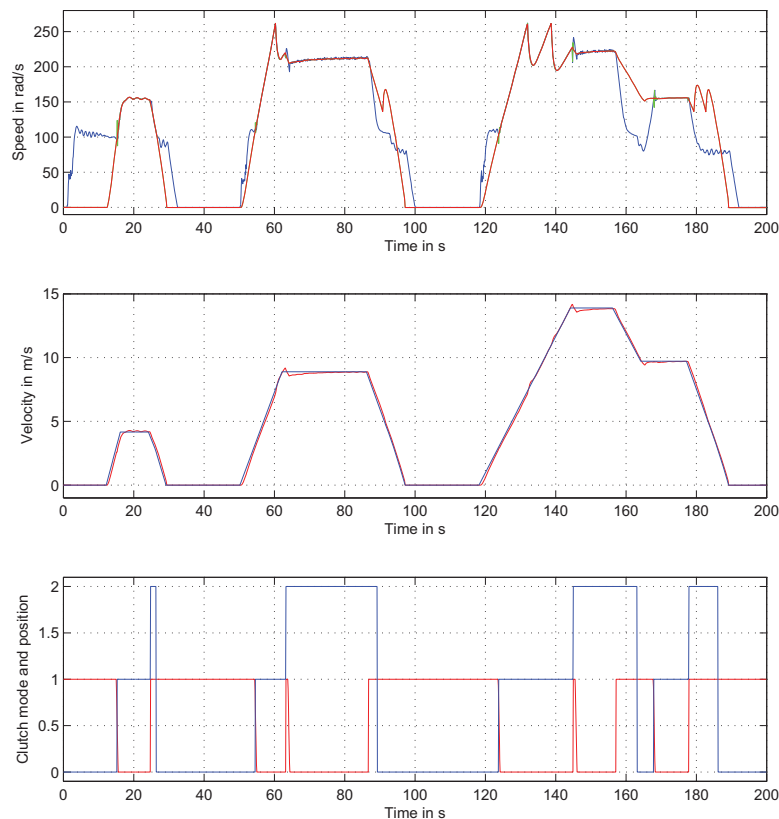

Figure 8: HiL Simulation Results: top: ICE speed (blue) and gearbox speed (green), speed of the second clutch plate (red), middle: desired (blue) and actual vehicle speed (red), bottom: clutch mode (blue: 0 - open, 1 - closed, 2 - reopening) and position (red: 1 - pedal pressed, 0 - pedal not pressed)

After about 1 second the engine is started by using the starter of the engine and operated at an idle speed of approximately 100 rad/s. After another 14 seconds the desired vehicle velocity (blue) is increased according to the NEDC and so the normalized clutch pedal position (red) changes from 1 (clutch pedal pressed) to 0 (pedal released). This leads to a transition from clutch state 'open' to 'closed'.

After 25 seconds the clutch is reopened and the clutch state changes to 'reopening' (3). The simulated HEM is then used to brake down the vehicle and to recover the kinetic speed of the car, which is subsequently stored in the

simulated hybrid battery.

As soon as the relative speed between the clutch plates exceeds a threshold of 40 rad/s the clutch state changes to 'open'. The vehicle is decelerated to zero velocity and the engine is subsequently shut down and restarted after a few seconds to accomplish the rest of the city cycle.

5 Conclusion

In this contribution a new hybrid dynamic model of a vehicle clutch for online HiL simulation is presented. This new model is advantageous to previously published models since it is able to describe the real behavior of the clutch in an more accurate way, as the model incorporates a speed-depending friction coefficient as well as a rotational-damper-element.

Since the external function is programmed by using the standardized programming language C, the dynamic model of the vehicle clutch can be easily adapted to other simulation environments like MATLAB/Simulink and others. Another advantage of the presented approach is the high customisability of the clutch's behavior by adapting an individual set of clutch parameters.

6 References

- [1] A. Kleimaier et al. Hybrid cars, optimization and control. *Proceedings of the IEEE International Conference on Industrial Technology*, pages 1084–1089, 2004.
- [2] Ali Boyali et al. Modeling and control of a four wheel drive parallel hybrid electric vehicle. *Proceedings of the IEEE International Conference on Control Applications*, pages 155–162, 2006.
- [3] David Wenzhong Gao et al. Modeling and simulation of electric and hybrid vehicles. *Proceedings of the IEEE Vol.95*, pages 729–745, 2007.
- [4] G. Wanner E. Hairer. *Solving Ordinary Differential Equations II*. Springer Series in Computational Mathematics. Springer Verlag, Berlin, Heidelberg, 2. edition, 1991.
- [5] Thomas Prachar et al. Consideration of different hybrid powertrains with the help of a model in longitudinal dynamics using dymola. *Proceedings of the SAE 2006 World Congress and Exhibition*, 2006.
- [6] Jonathan Chauvin et al. Real-time combustion torque estimation on a diesel engine test bench using an adaptive fourier basis decompositon. *Proceedings of the 43rd IEEE Conference on Decision and Control*, pages 1695–1702, 2004.
- [7] Jonathan Chauvin et al. Real-time combustion torque estimation on a diesel engine test bench using time-varying kalman filtering. *Proceedings of the 43rd IEEE Conference on Decision and Control*, pages 1688–1694, 2004.
- [8] R. Beck et al. Model predictive control of a parallel hybrid vehicle drivetrain. *Proceedings of the 44th IEEE Conference on Decision and Control and the European Control Conference*, pages 2670–2675, 2005.
- [9] Siegfried Helm et al. Hardware in the loop simulation of a hybrid power train. *Proceedings of the 2008 International Simulation Multi-conference, Edinburgh*, 2008.