

CONCEPTUAL MODELLING OF CONTINUOUS - DISCRETE PRODUCTION SYSTEMS

Nenad Perši, Vesna Dušak

University of Zagreb, Faculty of Organization and Informatics,
42000 Varaždin, Pavlinska 2, Croatia

nenad.persi@foi.hr (Nenad Perši)

Abstract

Complex system dynamic, structure and behaviour performances asks wide range of methods, algorithms and tools to reach model capable for searching optimal performing parameters. In the modelling process, it is up to analyst to select appropriate combination of methods, algorithms and tools to express significant system performances. Such methodology for designing complex systems should be based upon conceptual modelling to perform sensitive analyse of different system levels and views, allowing system representations for developing computer models.

Complex systems, such as business systems with continuous-discrete production process are demanding well organised supply chain highly reactive to production assortment changes. Aligning two different production components, distinctive in their behaviour, is especially sensitive in production parameters transition point. Such system performances request distinctive designing methods that could follow double behaviour nature of production process according to their entities dynamics, caused by assortment changes. Consequently, such systems need different conceptual presentations to realise its purpose from different views and aspects. Paper is based on results derived from project of parameters optimisation in glass industry.

Simulation modelling principles, methods and tools are solid environment for wide range of conceptual models developing to improve system performances. They offer qualitative and valuable results based upon large quantity of processed and verified data, as well as on the large number processed and checked possible problem solution variants. Upon those facts, choosing optimal processing parameters is done more qualitatively, and following implementation of new solution take benefits and leads to expected business results.

Keywords: Complex production systems, Conceptual modelling

Presenting Author's biography

Nenad Perši is Senior Assistant of Simulation Modelling and Operations Research at Faculty of Organization and Informatics, University of Zagreb, Croatia. He received his M.Sc. and Ph.D. in simulation modelling at University of Zagreb. His main research is in aspects of complex manufacturing systems but also in aspects of genetic algorithms, expert systems and practical use of simulation. His e-mail address: nenad.persi@foi.hr



1. Complex systems researching methodology

Today's methodologies for analysing, modelling and (re)designing complex systems do not strictly define its concepts and contents, and push analysts to choose one, proper to system structure, behaviour and dynamic, what is specially important in the case of complex systems. System complexity could be seen from different aspects according to their structure, behaviour and dynamic [4]. As complex systems are often systems with transitive production processes behaviour, sensitive to assortment changes, they require consistent methodology which should allow:

- ♦ production process modelling according to its component specifics in behaviour, structure and dynamic,
- ♦ developing the overall production process model without losing component specifics and including environmental influence,
- ♦ representing overall production process dynamic,
- ♦ different system states investigation in searching for optimal process parameterisation, and
- ♦ developed model valuation, verification and approving on structuring, functionality, reality and reliability, and predictability.

Such methodology includes a range of different modelling methods and tools according to system components behaviour, structure and dynamics (to solve described problem, different concepts are implemented: Petri Net, Activity Cycle Diagram, Causal Loop Diagram, Flow Chart Diagram, Transition Diagram). Also, it should able:

- ♦ entities transition from state to state followed by metrology alignment,
- ♦ different behaviour presentation according to subsystems components characteristics,
- ♦ processes parameterisation and formalisation appropriate for using information technology to perform improving process.

All these requests on complex system research methodology should be based on process approach and should allow simulation modelling. Process approach should assure correct process structuring, entities relationships, and performances description on which simulation modelling techniques could develop complex system model [6]. As simulation modelling includes techniques for developing models of continuous and discrete systems it could support behaviourally different system components, and also, over transition point, it could provide smooth flow between those components.

Simulation also could represent systems on different levels. Conceptual models offer system representation in the way which is appropriate to system behaviour and structure to elicitate the most important specialities, but also entities dependencies. Using

mathematical, statistical and algorithmic presentations, computer models could be developed. In this way, simulation modelling becomes powerful tool for experimenting with the systems states, parameters aligning, and choosing the most appropriate production mode.

According to modelling levels, combination of process approach and simulation modelling also allows meta-models developing in the process class abstraction meaning. With concrete processes parameterisation such class of models became a real world applied process model.

As real world processes run in some environment they are not well described only over inner parameters. Parameters from system environment should also be included in system modelling. After outer influence is determine on system and processes level, simulation model could include them in the system model in order to investigate its influence on system states changing.

2. Specifics of continuous - discrete production process sensitive to production assortment demands

Production business systems are represented by a set of processes determined with scope and specific production technology of material products made for a stock, according to order or assemble to order. According to the processes specifics, production technology is determined by continuous (products are measured by weight and volume measures), discrete (products are measured by pieces) or combined set of products flows.

The important characteristic of the continuous-discrete class of production is the lack of the unique product measure over production process. That is caused by significant change of system characteristics and requires specific approach to system analysing and modelling for each production component or phase (continuous or discrete). Also it requires component alignment in transition point to assure smooth overall production. Each production component has its own goals and the way of succeeding [7].

Usually, the continuous production phase is determined by the capacity of the main resource for preparing the basic material for final products (cooked chocolate, melting glass,...) and should keep special conditions on. Avoiding those conditions could cause fatal damage (frozen glass oven or unusable products). So, the main goal of continuous production phase is to keep constant production level according to technology conditions: product life time conditions (loss of functionality or some content component) or resource working conditions (always working "melting pot").

Discrete component determination is based on countable products and has its own dynamic, usually forced by orders. The range of products differentiation is much more pointed out in this phase. In the continuous phase significant role has product content and quality of this contents (glass colour and prescription), but in discrete phase the most important role has products shape and combination with some addings (shape of bottles, variety of glass products etc.). So, in this phase there are resources mostly focused on products design and creating their functionality. The pace of this phase is dictated by orders, but also by continuous phase resource capacity.

According to described characteristics of continuous-discrete production systems (CDPS) forced by orders, CDPS's are complex systems according to their component behaviour, structure, dynamic and way of managing, and they need specific research methodology, based on process approach and simulation modelling, for their analysing, modelling and (re)designing [3].

There is a wide range of production process type CDPS, from food industry to the civil engineering and some raw materials for road industry. In this article we developed conceptual and computer simulation model for CDPS class forced by orders, model for glass production.

All those performances of CDPS class required managing process sensitive on range of varieties in the system. From the different production phases there are two optimal points, differently defined for each component (continuous and discrete). From the continual phase point of view goal is focused on resource characteristics and controlling to assure smooth process without turbulences that could it break. To predict followed process stages, and assure on time enough inputs of determined quality is the goal of continuous production phase [8]. The goal of discrete production phase is to exploit all material made in continuous phase according to variation in demands.

Separate production phases' optimisation do not produce optimal solution for overall system. And that is the main point of complex system designing. To align two different systems in the way of reaching overall optimal solution is the result expecting from (re)designing of complex system.

3. Glass container manufacturing model

The glass container manufacturing process is a sequence of processes and activities performed both in a continuous and discrete way. Therefore, the entire system needs to be represented by means of two separate models. There are different ways on which production process occurs in each of them. Moreover, such a division is notable within the business system

itself, so processes and activities pertaining to each of the two production types are easily discernible [1].

3.1. The conceptual model of the hot zone

The term conceptual model refers to a rough description of a system further elaborated into individual modules. This model type is the first formal description of a system used in simulation modelling for identifying connections and relationships between entities within the system, which is essential for a further formal description of system functioning by means of a computing simulation model.

The hot zone consists of the preparation and melting of the glass mass and forming of glass containers. The glass mass preparation and melting stage contain two mutually connected business activities. The performance of each of those activities affects the execution of the other. For each of the two activities it is necessary to develop their own conceptual model. The conceptual model itself can be developed in many ways. Owing to the nature of the continuous manufacturing process which virtually never comes to a halt, it is hard to determine the beginning of such a process. However, it is possible to consider the input of raw materials as the beginning of the manufacturing process. In Figure 1 the entire hot zone is shown with activity cycle diagram (ACD).

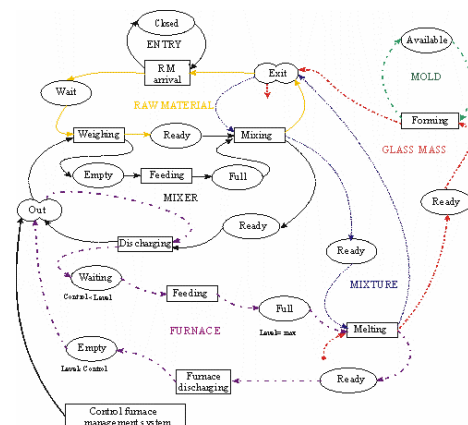

Fig. 1 Hot zone activity cycle diagram

The purpose of the activity cycle diagram of hot zone is states recognition and events correlation in the whole continuous production process. Diagram contents flow and causal-consequential relations between related events and states of each present entity. Anyway, because of special system attributes, ACD diagram is not enough precise, specially in part presenting production system control mechanism.

The another way to present hot zone manufacturing processes on conceptual level is Petri Nets. They are more complex method for conceptual modelling of business systems with higher precision. In Figure 2 the entire hot zone Petri Net is shown.

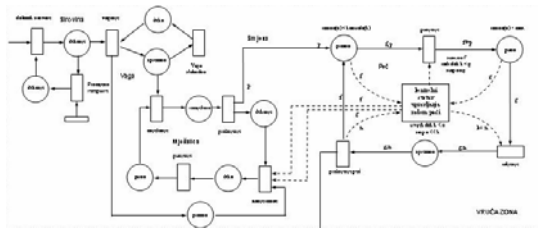

Fig. 2 Hot zone Petri Net

Petri Nets, as more complex conceptual model, in addition, solves inexactnesses of using ACD. Petri Nets shows possible resources conflicts and the way of their resolution. Also, they points out solutions for dead-locks, states conversion present conflicts accomplishment, and similar adverse system states. Petri Net, specially coloured Petri Net, describes very precisely system states conditions (continuous process with feed-back), including process network net, the way of performing processes and states conversion.

The synergy effects of those two representation is to elicitate logical flows of hot zone entities and the way of managing furnace. ACD diagram describes simple events and system states, and Petri Net precisely describes complex conditions for events realisation and states conversion. In combination of two described diagrams, all main advantages of conceptual modelling on different system level are pointed out.

3.2. The conceptual model of the cold zone

The term cold zone refers to the part of the glass manufacturing process which encompasses the final processing of glass containers until they are delivered to the finished goods warehouse (Figure 3).

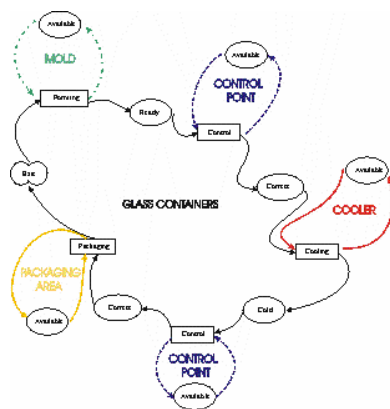

Fig. 3 Cold zone activity cycle diagram

ACD diagram of hot zone represents discrete part of production process. As in the case of continuous part (hot zone) diagram represent basic events and entities states.

In this part of the manufacturing process glass containers undergo several sequential processing stages before their final delivery to the warehouse, without changing its features in the process (the GLASS CONTAINERS entity is not transformed into

a new form until the end of the process, and thus does not generate a new entity). The glass containers formed in the hot zone at the end of the process becomes the object of processing in the cold zone. Here manufacturing processes and activities occur sequentially, but discontinuously, with each particular glass container initiating a certain event, that is, a system state change.

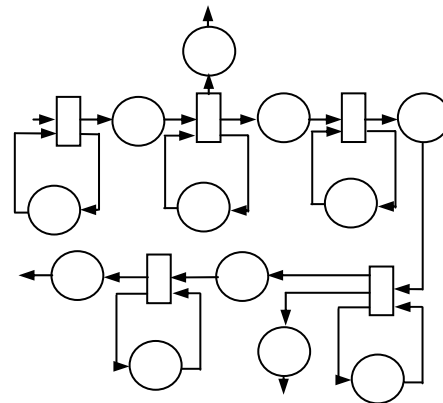

Fig. 4 Cold zone Petri Net

Petri Net representing cold zone is simple net of Place/Transition type, describing possible events using elements with strictly determined capacity. Associated flows are marked by defined weights.

3.3. The computing model of the hot zone

Manufacturing processes in the hot zone are continuous and can therefore be shown by means of systems dynamics or, more precisely, a negative feedback model (process management is done in accordance with the predefined parameter limit values, with actions initiated by variable values exceeding the predefined limits with a view to stabilising the system). In a business system negative feedback management and action initiation are completely automated. The human factor, on the other hand, supervises the operation of the automated management system and monitors its operations over a period of time. The management and monitoring system is a part of the FURNACE entity and has been called a control furnace management system. The function of this system is to monitor the parameters of technological production of glass in the melting furnace and accordingly emit control management signals for processes occurring during glass mass preparation and furnace feeding.

Figure 5 shows the systems dynamics of glass mass preparation and melting processes monitored by the control management mechanism.

Generally speaking, this model shows a self-regulating negative feedback, so that the control function of the furnace management system cannot be discerned from this diagram showing glass mass preparation and melting processes. In the same time

causal loop diagram is base for programming code for essential part of continuous simulation model.

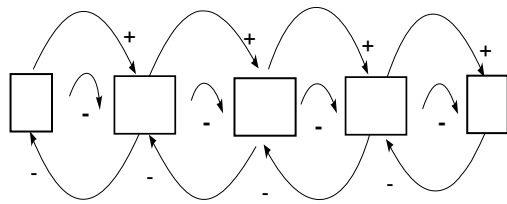

Fig. 5 Causal loop diagram of glass mass preparation and melting processes

Simulation managing programming lays on conditions describing by transition state diagram connected over furnace management control system.

The control function of the furnace management system is based on the tolerance of the level of glass mass melted in the furnace as the control parameter (Figure 6).

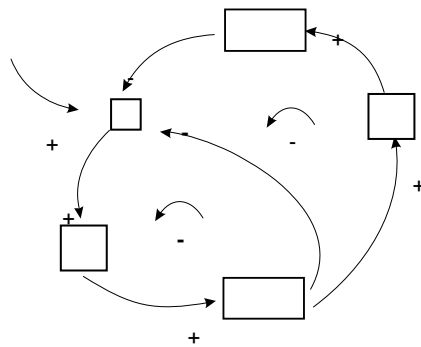

Fig. 6 Furnace management control system

It is recommended to describe all system parts or phases in the same way of representation for better system flows and architecture understanding in the very beginning of system formalisation. In presenting case for such purpose is used ACD for both, continuous and discrete system phase. That allows transition point determination. Transition point is described with entity mold separating the whole system in to different recognisable wholes followed by assigned conceptual models.

Both zones are described with Petri Nets. In that way, production process control mechanism, specially for continuous part, is described more detailed. Petri Nets gave a new view on process and its formalisation in the computer recognisable way.

Computing model is done with simulation tool allowing system dynamic simulation: system dynamics concepts formalisation based on statistical-mathematical notation.

Nowadays simulation tools are object oriented. Code generation performing is based on flow diagram in graphical environment with computing model parallel

definition. Flow diagram uses graphical elements marked as Level, Rate, Auxiliary, Constants and initial values. Levels, constants, states transitions and auxiliary equations are connecting in circles by flows showing system dynamics. Entity object definition is presenting by graphical symbol assigned to concrete variable from conceptual model. Each of them could be formalised with mathematical equations.

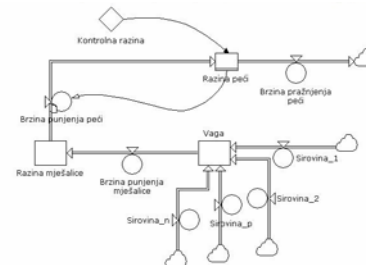

Fig. 7 Simulation model of cold zone

3. 4. The computing model of the cold zone

The cold zone includes a sequence of manufacturing operations encompassing the manufacturing of each particular glass container. Within a business system, this part of production occurs continuously, with certain events being influenced by transactions of individual glass containers. Therefore this part of the manufacturing process can be described by a discontinuous simulation model. The transition from a continuous to a discontinuous part of manufacturing occurs in the MOLD entity. In other words, it is at this very part of the manufacturing process that the transition from a continuous simulation model to its discontinuous counterpart takes place. The hot zone model is thus strictly defined and guided and no major deviations in it are allowed or, for that matter, possible. This fact enables for a more complex, continuous model to be substituted by a simpler, discontinuous one. For that an unambiguous variable that will properly represent both models needs to be defined. Owing to the specific features of the glass container manufacturing system, this variable has been defined as the total quantity of the available melted glass mass. This variable can be expressed by the same units of measurement in both models and acts as a linking variable between the two models as it represents the exit from the continuous and the entry into the discontinuous model. Figure 8 shows a cold zone model.

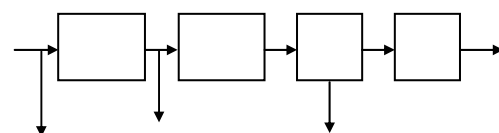

Fig. 8 Glass container production line

Computing model is done with simulation tool for discrete system simulation. It is useful for solving

problems connecting with tuning of business operations (reaching minimum operation costs queuing times, or increasing resource utilisation and service quality). Modern tools are program packages with repository of general program routines and objects that optimise programming phase.

According to collected data, there is computer simulation model for each product or product combination production, using for performing simulation experiments.

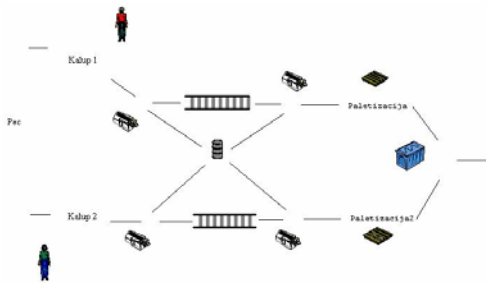

Fig. 9 Simulation model of cold zone

4. Conclusion

Complex system research methodology requests recent specialist acknowledgment in system modelling and organisation engineering to reach optimal performing parameters values. According to complex system dynamic, structure and behaviour performances variation, their modelling asks wide range of methods, algorithms and tools to reach valuable model capable for searching optimal goals levels. Consequently, such systems need different conceptual presentations to realise its purpose from different views and aspects. So requested methodology should allow:

- ♦ system structure representation on general and partially levels,
- ♦ processes dynamics nature and behaviour (including transition points) recognition,
- ♦ system states and parameters formalisation leading to computer models development,
- ♦ environment influence recognition
- ♦ verification, validation and parameters range derivations of values requested for system purpose realisation.

Conceptual models offer a lot of possibilities for system representation and formalisation on the way to survive in concurrent reality. Conceptual models could represent systems in different levels. They offer system representation appropriate to system behaviour, structure and dynamic to elicitate the most important specialities, but also entities dependencies. Using mathematical, statistical and algorithmic presentations, computer models could be developed.

In this way, conceptual modelling becomes powerful tool for experimenting with the systems states, parameters aligning, and choosing the most appropriate production mode.

According to modelling levels, combination of process approach and conceptual modelling also allows developing of wide range meta-models. With concrete process parameterisation, such models became representation of a real world applied process model, appropriate to investigate optimal parameter values. As it was discuss in paper, simulation modelling principles, methods and tools are recommendable as proper way of experimenting in virtual world for real world purpose.

References

- [1] Bider I.: Choosing Approach to Business Process Modeling – Practical Perspective; Journal of Conceptual Modeling, Issue 34; 2005.
- [2] Dewhurst, F., Barber, K., Rogers, J.J.B., Towards integrated manufacturing planning with common tool and information sets, International Journal of Operations & Production Management, Vol 21, No 11 2001, pp. 1460-1482.
- [3] Ingemansson, A., Bolmsjö, G.S., Improved efficiency with production disturbance reduction in manufacturing systems based on discrete-event simulation, Journal of Manufacturing Technology Management, Vol 15, No 3 2004, pp. 267-279.
- [4] Jiming L., XiaoLong J., Kwok C.T.: Autonomy Oriented Computing: From Problem Solving to Complex Systems Modeling; Springer 2004.
- [5] Kunnathur A. S., Sundararaghavan P. S., Sampath S.: Dynamic rescheduling using a simulation-based expert system; Journal of Manufacturing Technology Management; Vol. 15 Number 2; 2004.; pp. 199-212
- [6] Lau, H.Y.K., Mak, K.L., The design of flexible manufacturing systems using an extended unified framework, Journal of Manufacturing Technology Management, Vol 15, No 3 2004, pp. 222-238
- [7] Manzini, R., Ferrari, E., Gamberi, M., Persona, A., Rigattieri, A., Simulation performance in the oprimisation of the suppli chain, Journal of Manufacturing Technology Management, Vol 16, No 2 2005, pp. 127-144.
- [8] Visawan D., Tannock J.: Simualtion of the economics of quality improvement in manufacturing; International Journal of Quality & Reliability Management; Volume 21 Number 6; 2004.; pp. 638-654
- [9] Wang, Z., Zhang, J., Chan, F.T.S., A hybrid Petri nets model of networked manufacturing systems

and its control system architecture, *Journal of Manufacturing Technology Management*, Vol 16, No 1 2005, pp. 36-52.

task allocation for holonic manufacturing system; *International Journal of Advantage Manufacturing Technology*; Volume 32; 2007; 1021-1032

- [10] Wenbin Z., Juanqi Y., Dengze M., Ye J., Xiumin F.: Production engineering-oriented virtual factory: a planning cell-based approach to manufacturing system design; *International Journal of Advantage Manufacturing Technology*; Volume 28; 2006; 957-965
- [11] Zhao F., Hong Y., Yu D., Zhang Q., Yi H.: A hybrid algorithm based on particle swarm optimization and simulated annealing to holon